

Vom selben Team, das auch **Kloster Dance 2024** produziert hat!



Liebe Tänzer/innen!

Wir laden Euch recht herzlich ein zu unserem Tanzabend

Kloster Dance 2025

am **5. April 2025** um 19 Uhr
im evgl. Gemeindehaus Moers-Meerbeck,
Bismarckstr. 35b, 47443 Moers

Euer Einsatz: 18 Euro (incl. Buffet)

≈≈≈

Programm

Bourneham Hall
Always on my Mind
Mercat Cross

Bea's Delight
Barley Bree
Asilomar Romantic

Grant's Hornpipe
Elephant's Stampede
Eifel Welcome

Hooper's Jig
Milton's Welcome
Latvian Lass

Happy Dancing
Scott Meikle
Leisurely Stroll

Smiling Lila
A Capital Jig
Pride of Thistle

Extra: Rest and be Thankful

Anmeldung: storkthomas@aol.com, Stichwort „Kloster Dance“



Das Programm und alle anderen Details findet Ihr demnächst auch auf unserer Seite www.swinging-kilts.de. All denen, die in unserem Email-Verteiler sind, schicken wir es sowieso zu. (Schickt eine Mail an storkthomas@aol.com, wenn Ihr bisher noch nicht in unserem Verteiler seid.)

Unser Tanzabend findet wie im letzten Jahr hier statt:
(Wegbeschreibung und besseres Bild demnächst auf unserer Webseite.)

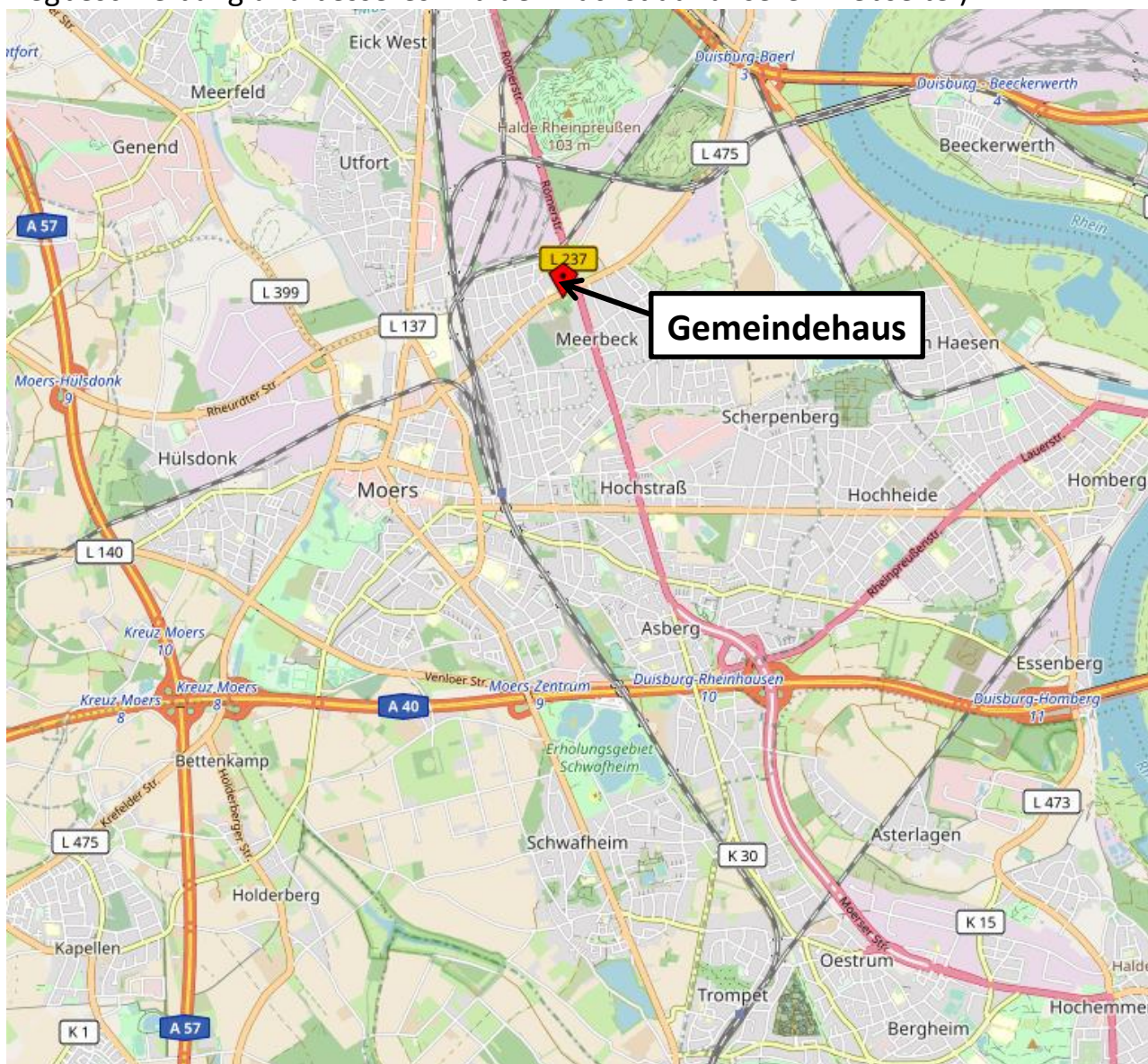

Happy Dancing wünschen



The Swinging Kilts

KlosterDance 2025

Bourneham Hall
Always on my Mind
Mercat Cross

Bea's Delight
Barley Bree
Asilomar Romantic

BUFFET

Grant's Hornpipe
Elephant's Stampede
Eifel Welcome

Hooper's Jig
Milton's Welcome
Latvian Lass

Happy Dancing
Scott Meikle
Leisurely Stroll



Smiling Lila
A Capital Jig
Pride of Thistle

Extra: Rest and be Thankful

KlosterDance 2025

BOURNEHAM HALL (J 8x32) 3C (4C set)

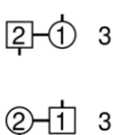

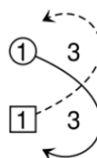
- 1- 8 1s cross RH, and cast off; turn with right hands (retain hands)
- 9-16 1s and 3s dance right hands across (1st man stay facing out); 1st man turn 2nd lady and 1st lady turn 2nd man with left hands (men stay facing out)
- 17-24 2s and 1s dance Ladies' Chain
- 25-32 1s dance a figure of eight round 3s; all three couples turn with right hands

BOURNEHAM HALL				8x32 J	
X_R 	T_R	1x3  RA	T_L	2 1x 	 T_R

3C/4C longwise set.

ALWAYS ON MY MIND (R8x32) 3C (4C set) Yoshiki Oyama Tokai Branch 25th Anniversary

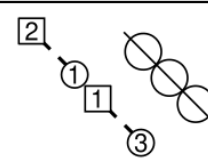
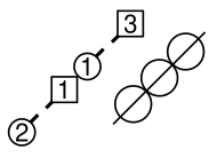
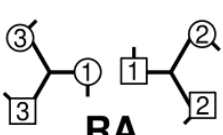
- 1- 8 1s set, cross RH, cast and turn $\frac{3}{4}$ LH to face 1st corners (2s step up 5-6)
- 9-12 1s dance 4 bars *Hello-Goodbye setting* (setting to 1st corners and partner) to face 2nd crnrs
- 13-16 1s dance $\frac{1}{2}$ diagonal reel of 4 with 2nd corners
- 17-20 1s dance 4 bars 'Hello-Goodbye' setting (setting to 4th corners position and partner) pulling back RSh to face 1st corner position
- 21-24 1s dance $\frac{1}{2}$ diagonal reel of 4 with corners
- 25-32 1s dance RH across, (1M with 3s, 1L with 2s). 3s+1s+2s chase $\frac{1}{2}$ round clockw to own sides.

ALWAYS ON MY MIND			8x32 R	
S X_R	 $T_L \frac{3}{4}$	S S		
S S		RA 		$3x$ $1x$ $2x$ 

THE MERCAT CROSS (S3x32) 3C set John Bowie Dickson Dunedin Dances Book 3

- 1- 8 1s+3s set; petronella turn into centre and dance $\frac{1}{2}$ reel of 4 in centre of dance
- 9-16 1M+3L (centre couple) dance LH across with 2s while 1L+3M chase clockwise $\frac{1}{2}$ way; 1s+3s dance $\frac{1}{2}$ reel of 4 in centre of dance
- 17-24 1M+3L (centre couple) dance LH across with 2s as 1L+3M chase clockwise $\frac{1}{2}$ way; 1s+3s turn RH $1\frac{1}{4}$ times ending with 1s facing down
- 25-32 1s+2s dance the Rondel but on bars 29/32 3s set advancing to make an arch and dance up to 2nd place as 1s dance under to 3rd place. 231

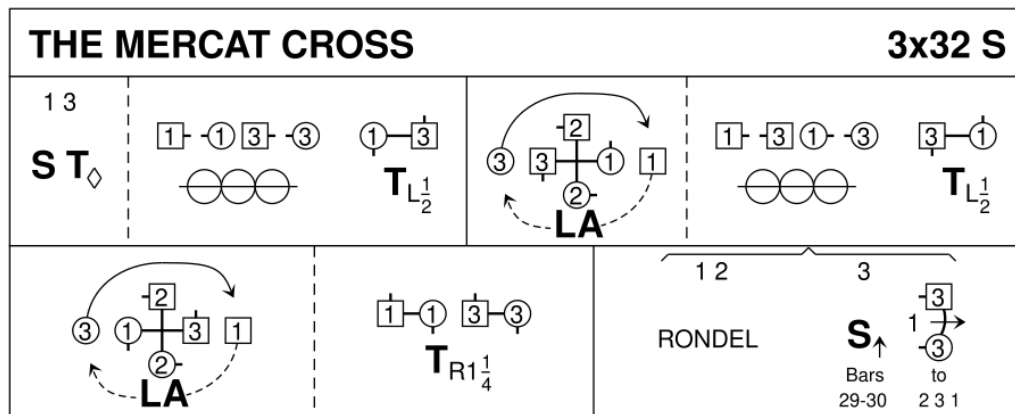

John Bowie Dickson, 1993, Dunedin Dances 3

3C/3C longwise set.

BEA'S DELIGHT (R8x32) 3C (4C set) May MacFarlane RSCDS Book 43

- 1- 8 1L+2M turn RH to give LH to partner and Balance-in-Line, 1L followed by partner casts 1 place (Men's side) and crosses to end 2nd place own sides while 2M followed by partner casts up (Ladies' side) and crosses to 1st place own side
- 9-16 2s+1s+3s dance reels of 3 on sides (1s RSh to 3s to start)
- 17-24 1s repeat bars 1- 8 with 3s
- 25-32 1L dances behind 3L, in front of 2L and casts to 2nd place while 1M dances in front of 3M, behind 2M and dances down to 2nd place, 2s+1s+3s set

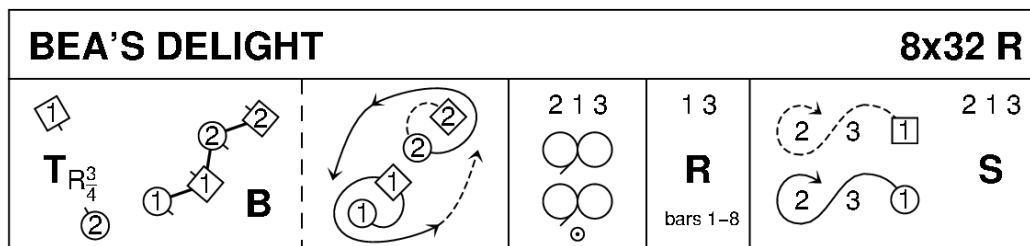

May Macfarlane, 2000, RSCDS Book 43.7

3C/4C longwise set.

BARLEY BREE (J4x40) 4C set RSCDS Book 13

- 1- 8 All advance and retire and cross over (Men making arches)
- 9-16 All advance and retire and cross (Ladies making the arches)
- 17-24 1s turn RH 1½ times, turn 2s LH on sides, 1s turn RH in middle
- 25-32 1s turn 3s LH on sides, 1s turn RH in middle, 1s turn 4s LH on sides and 1s ½ turn RH in middle and form arch
- 33-40 2s followed by 3s and 4s, cast to bottom and lead up under arch. 2341

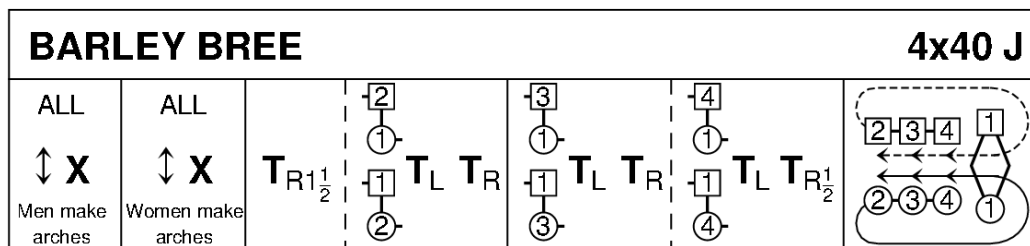

RSCDS Book 13.4

4C/4C longwise set.

ASILOMAR ROMANTIC (S8x32) 3C (4C set) Tom Cuthbertson San Fransisco Collection 2

- 1- 8 1s+3s dance double Fig of 8 around 2s, 1s crossing down, 3s cast up to start
- 9-16 1s+2s dance Poussette
- 17-24 1s dance in and down between 2s (2s step up), set to each other and dance RSh round 4th corner to face own 1st corner
- 25-32 1s dance 'Hello-Goodbye' setting ending with petronella turn to 2nd places. 213

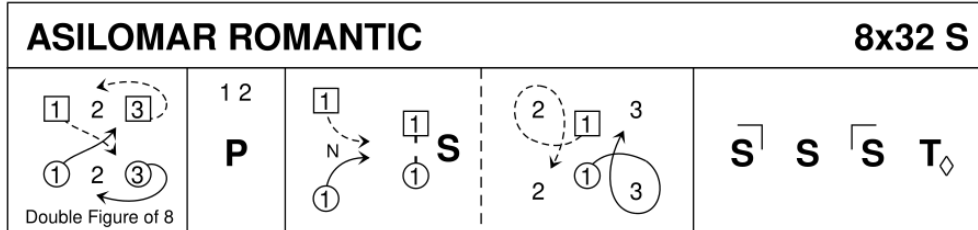

GRANT'S HORNPIPE (H 8x32)

- 1-8 1M and 2L set and cross right, while 1L and 2M cross right and set; repeat back to places
- 9-16 1s dance down the middle (nearer hands) and back; stay in the middle facing up for ...
- 17-24 cast into 2nd place and dance back-to-back
- 25-32 2s and 1s dance rights and lefts

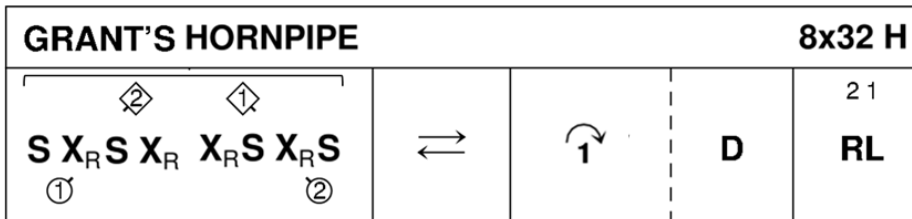

THE ELEPHANT'S STAMPEDE (J4x48) Sq.Set MacDonald/Aurora 10th Anniversary Book

- 1- 8 All circle 8H round and back
- 9-16 1s+3s advance nearer hands joined and with free hand join with 2s and 4s, retire into longwise set across the dance; all dance 1/2 parallel RSh reels of 4 across
- 17-24 All dance 1/2 R&L at each end of set (across to start); end couples and middle couples turn RH 1 1/2 times to form Sq.Set
- 25-32 All Ladies petronella turn to next Ladies' place to right and set, repeat to meet partner (all have progressed 1 place to right), Ladies face out
- 33-48 All dance full Schiehallion Reel. 2341

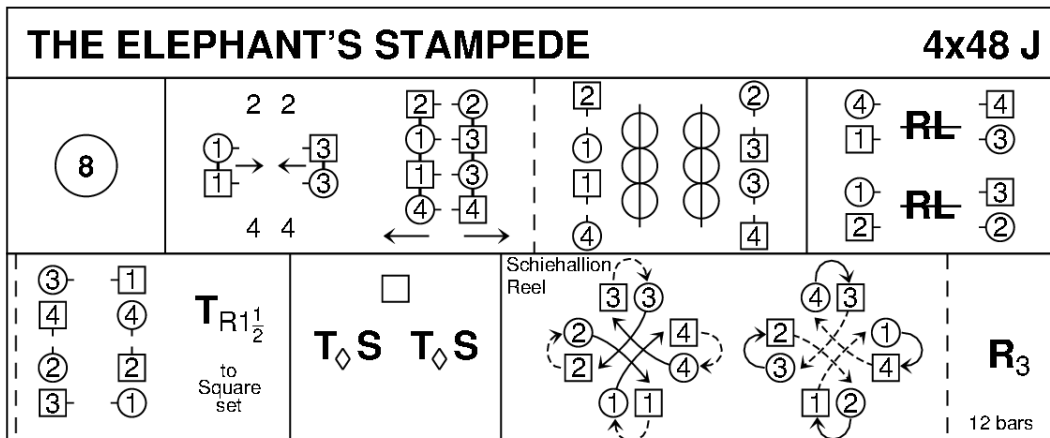

THE EIFEL WELCOME (S8x32) 3C (4C set) Rudolf Spägle

- 1- 8 1s cross RH and cast 1 place, cross RH and cast right (1M ends between 2s, 1L ends between 3s)
- 9-12 1s in lines of 3 advance and retire (for 1 up/down) and change places RH
- 13-16 All repeat bars 9-12
- 17-24 1s cross RH and cast to 2nd place own side, 1s turn RH
- 25-32 2s+1s+3s circle 6H round and back

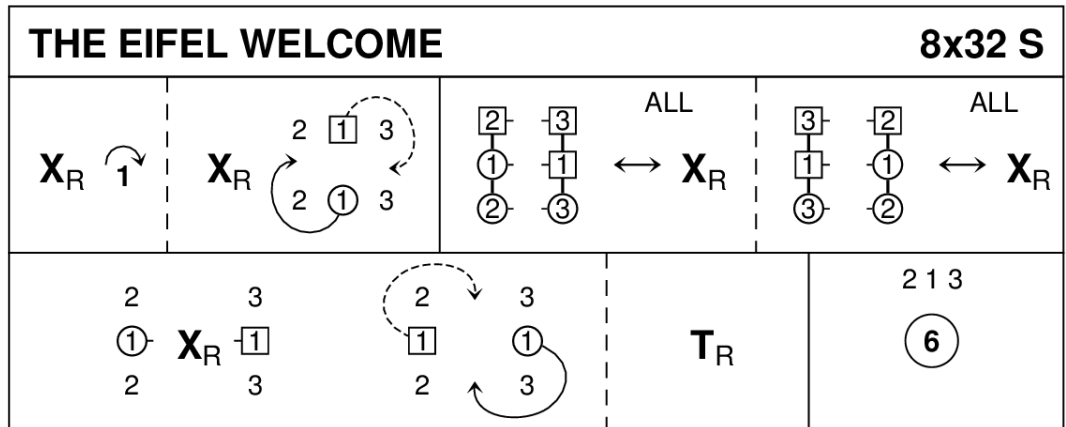

Rudolph Spägle, 2009

3C/4C longwise set

HOOPER'S JIG (J8x32) 3C (4C set) MMM 2

- 1- 8 All clap and 1s cross passing RSh, cast to 2nd place and dance RH across with 3s
- 9-16 All clap and 1s cross passing RSh, cast to 1st place and dance LH across with 2s
- 17-24 1M+3L change places RH and 1L+3M change places RH (as 1M+3L loop round), 1M+3L change places RH (as 1L+3M loop round) and 1L+3M cross LH 1L ending in 2nd place (as 1M casts to 2nd place), 2s step up on bars 23-24
- 25-32 2s+1s dance R&L. 213

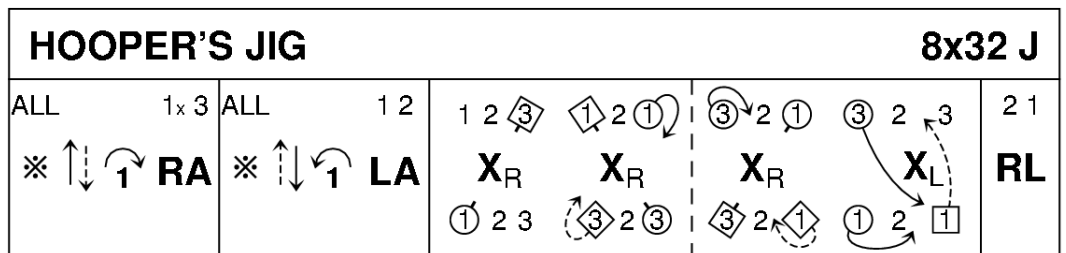

MILTON'S WELCOME (R8x32) 3C (4C set) John Bayly RSCDS Book 33

- 1- 8 1s+2s+3s set, cross RH, 1s+2s+3s set and 1s+3s 3/4 turn RH (to form line up and down centre) as 2s cross RH to original places
- 9-16 1s+3s dance reel of 4 in centre of dance end with 1L+3M taking LH as partners end on sides
- 17-24 1L+3M 3/4 turn LH to face own sides, dance out and cast behind 2s to original places, 1s+2s+3s turn LH
- 25-32 1s+2s dance Poussette. 213

MILTON'S WELCOME			8x32 R		
$\overbrace{1\ 2\ 3}^{\text{1x}}$ S X_R S	$\overbrace{1x\ 2x\ 3x}^{\text{2x}}$ T_R³₄ X_R T_R³₄			$1\ 2\ 3$ T_L	$1\ 2$ P

LATVIAN LASS (M-8x(S16+R16)) 3C (4C set) RSCDS Boston Celebrate 50 years

Strathspey

- 1- 8 1s lead down, L turns under M's arm to change places, lead up and turn RH to face 1st corners
 9-16 1s dance ½ diagonal reel of 4 with 1st corners, turn 2H to face 2nd corners, dance ½ diagonal reel with 2nd corners and ½ turn 2H and pass RSh to face own side BtoB for Double Triangles

Reel

- 17-24 1s dance Petronella Triangles (1s dance Double Triangles as corners set and petronella on 1 place to right and repeat), 1s end facing 2nd corners positions
 25-32 1s dance RSh reels of 3 across (Man with 2s and Lady with 3s)

THE LATVIAN LASS		8x(16 S + 16 R)	
<i>Strathspey</i> <p>L under M's R arm</p>			
<i>Reel</i> 			<p>to 2 1 3</p>

HAPPY DANCING (J8x32) 3C (4C set) Yoshie Kajino Tokai Branch 25th Anniversary

- 1- 4 All clap, 1s cross passing RSh and cast (2s step up)
 5- 8 1s pass RSh, pull back RSh and dance out to 2nd place own side, 1M facing up, 1L facing down.
 9-16 2s+1s+3s dance reels of 3 on own sides (1s RSh to 3rd corners)
 17-24 1s dance out round 3rd corners, pass RSh and curve into 2nd place own sides, while 2s+3s advance and retire diagonally and set twice
 25-32 2s+1s+3s circle 6H round to the left for 6 steps, pivot and chase back to places

HAPPY DANCING		8x32 J	
ALL 			
		$2\ 1\ 3$ Bar 28 Pivot 3 bars	$3x\ 1x\ 2x$

SCOTT MEIKLE (R4x32) 4C set Alice McLean Laurieston Collection 1 and RSCDS Book 46

1- 8 1s cross RH and cast to 2nd place, 1s dance ½ Fig of 8 round 2s

9-16 1s+3s dance RH across, LH back

17-24 1L followed by 3L dance Tandem reel of 3 across with 2s (LSh to 2M) and 1s end 3rd place while 3M followed by 1M dance reel of 3 with 4s (LSh to 4L) and 3s end in 2nd place. 2314

25-32 1s+4s dance ½ R&L, turn partners RH 1½ times. 2341

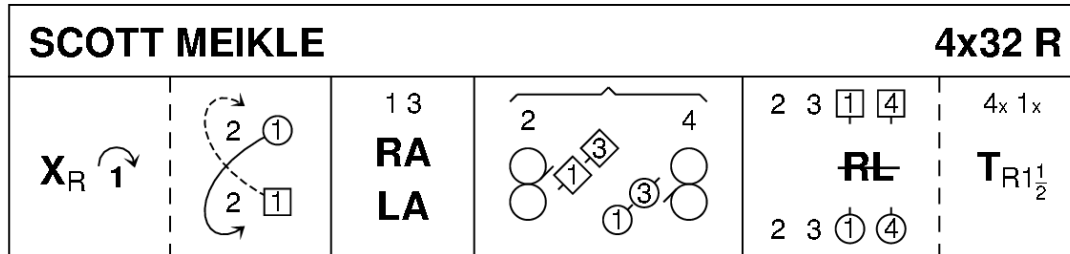

A LEISURELY STROLL (S8x32) 3C (4C set) Kaoru Oyama Tokai Branch 25th Anniversary

1- 8 1s dance Fig of 8 on own sides (dancing in and down to start)

9-16 1s+2s 'Set&Stroll':

1s and 2s set. 1L+2M cast pulling back RSh while 1M+2L dance to partner's places;

2M+1L dance round each other by the right, 1M+2L chase clockwise ½ way round. 213

17-20 All set, 2s and 3s Link as in set and link for 3 while 1s Petronella turn to diagonally right. (1L+3s facing down and 1M+2s facing up)

21-24 All set, 2s and 3s Link as in set and link for 3 while 1s Petronella turn to diagonally right. (3)(1)(2)

25-32 3s+1s+2s set in circle, dance into centre, pull RSh and dance out, chase clockwise half round to own sides. 213

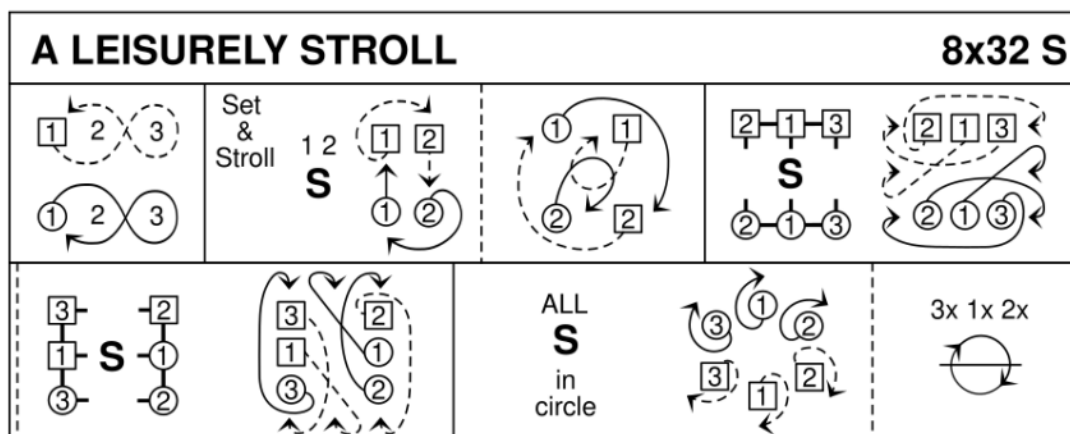

SMILING LILA (R8x32) 3C (4C set) Don Bartlett, 2017

1- 4 1s and 2s cross RH with partner and set to partners.

5- 8 1M+2M and 1L+2L Link on sides, join nearer hands with partner, 2s facing down, 1s facing up (213); 2s+1s set to each other

9-12 2s+1s Link with partners to finish 2s+1s joining nearer hands on the sides, facing partners. 2s+1s set to partners

13-16 1s nearer hands joined dance up between 2s and cast to 2nd place



17-24 1s lead down the middle and back, finishing in 2nd place facing up

25-32 *Modified reel of 3 on sides:*

1s dance out/up, 2s in/down, 3s in up to start.

Bar 3-4: On reaching 1st place, 1s cross down RH to continue reel on opposite side

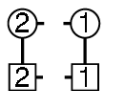
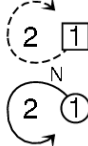
Bar 7-8: 1s cross up RH to end in 2nd place own side. 213

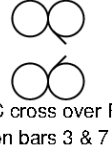
SMILING LILA				8x32 R	
1 2 X_R S	1x 2x LINK 	2x 1x 2 1 LINK S			 1C cross over R on bars 3 & 7

Don Bartlett, 2017

3C/4C longwise set.

A CAPITAL JIG (J8x32) 3C (4C set) Tine E MacKay 5 dances 2009



1- 8 1s+2s *set and rotate* and end 1s facing up, 2s down:

Set, rotate singly and dance on 1 place clockwise, change places RH on sides and dance on 1 place to own sides (1s in 2nd place facing up)

9-16 1s dance reels of 3 on own sides (RSh to 2s)

17-24 1s set and turn $\frac{3}{4}$ RH to face own sides, 1s dance LH across (1L with 2s, 1M with 3s) to end 2nd place opposite sides

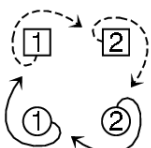
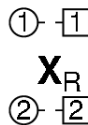
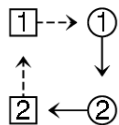
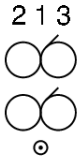
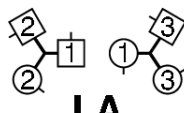
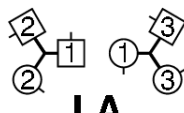
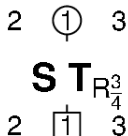
25-32 1s set and turn $\frac{3}{4}$ RH to face opposite sides, 1s dance LH across (1M with 2s, 1L with 3s) ending 2nd place own sides

A CAPITAL JIG			8x32 J	
Set and Rotate 1 2 S 			 2 1 3	
S T_{R$\frac{3}{4}$} 				

Tine Mackay, RSCDS 5/2009

3C/4C longwise set.

PRIDE OF THISTLE (S 3x32) Yoshiki Oyama

1-8 1s lead down. 1W pass under right arms to change place. 1s lead up. 1s cast off oppo sides to face 1st corners.

9-10 All (facing diagonal) set.

11-12 1s pull RS & change place to face 3rd corner places, 2s+3s dance ccw one place.

13-16 All repeat bars 9-12. 1s end in 2nd place opp (3x1x2x)

17-24 All joining NH set advancing & pass LSh to BtoB. All chase clockwise half to oppo sides. All cross RH (213)

25-32 1s+3s dance tournée.

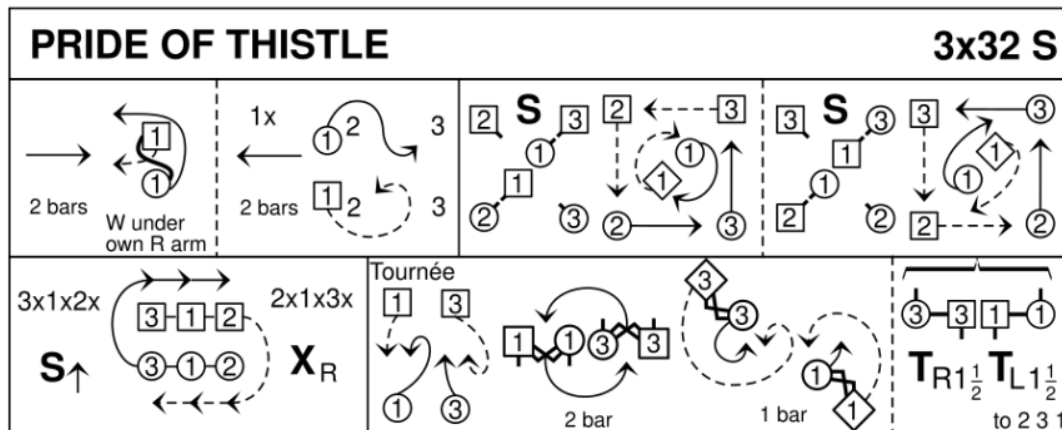

REST AND BE THANKFUL (R8x32) 3C (4C set) Grampian Collection

- 1- 8 1s cross RH and cast 1 place, cross LH and cast (Lady up and Man down) to meet 1st corners in prom hold
- 9-16 1s+1st corner dance ½ way round behind 2nd corner to 3rd corner while 2nd corners advance and retire diagonally;
1s leave 1st corners and turn 1¼ LH to meet 2nd corners in prom hold (1st corners now in diagonally opposite place)
- 17-24 1s dance with 2nd corner person ½ way round to 4th corner while 1st corners advance and retire;
1s leave 2nd corners and turn 1¼ LH to face 1st corner (position)
- 25-32 1s dance ½ diagonal Reel of 4 with 1st corners, pass RSh and dance ½ diagonal Reel with 2nd corners to end on own sides 2nd place

